



FITNESS AIM[™]

"Unleash your inner beast with FITNESS AIM"



www.arawatinternational.com



@FITNESS._AIM



+91-8384839044

Welcome to FITNESS AIM – Your Ultimate Destination for Premium Physical Fitness Goods!

Established in 2011, **Arawat International** proudly presents FITNESS AIM, your trusted manufacturer and exporter of top-tier physical fitness goods. With a steadfast commitment to quality, quantity, and customer satisfaction, we have become a leading name in the industry, catering to the diverse needs of athletes, sports enthusiasts, and fitness aficionados worldwide.

Under the brand name **FITNESS AIM**, we specialize in crafting high-performance equipment for athletics, track and field, gymnastics, as well as goals and posts for various sports. Our comprehensive range of products is designed to meet the rigorous demands of professional athletes and fitness professionals, while also catering to the needs of recreational users.

At FITNESS AIM, quality is our cornerstone. We are proud holders of **ISO 9001:2015** and **ISO 14001:2015** certifications, along with CE (**Certificate of Compliance**), REX, MSME, and GST registrations. These accolades underscore our unwavering commitment to adhering to the highest standards of quality and compliance in every aspect of our operations.

With a global footprint spanning over **16 countries**, including Italy, Switzerland, Malaysia, Mexico, Spain, Bulgaria, and Poland, among others, we have established ourselves as a trusted partner for clients seeking excellence in physical fitness goods. Our dedication to delivering superior products and unparalleled customer service has earned us the trust and loyalty of customers worldwide.

At FITNESS AIM, our mission is simple: to empower individuals to achieve their fitness goals and unlock their full potential. Whether you are a professional athlete, a fitness enthusiast, or a sports facility looking to upgrade your equipment, we have the perfect solution for you.

Explore our extensive range of products and experience the FITNESS AIM difference today. Join us on our journey towards a healthier, fitter world!



FITNESS AIM

Unleash your inner beast with FITNESS AIM

STRENGTH SERIES



UNLEASH YOUR INNER BEAST
WITH

FITNESS AIM



@FITNESS._AIM



COMMERCIAL

STRENGTH

Unleash Your Inner Athlete.
Power Your Gym!



PR SERIES

Embark on a journey of elevated strength training with the Prestige Pro line. Precision-crafted for peak gains and superior performance, these machines redefine your fitness achievements.



AIMPR

Prone Leg Curl

- Size - 1610*1095*1530mm
- Weight Stack - 110 kg
- Weight - 255 kg



AIMPR

Leg Extension

- Size - 1425*1165*1530mm
- Weight Stack - 110 kg
- Weight - 250 kg



AIMPR

Shoulder Press

- Size - 1550*1550*1530mm
- Weight Stack - 110 kg
- Weight - 260 kg



AIMPR
Rear Delt/Pec Fly

- Size - 1280*1430*2075mm
- Weight Stack - 95 kg
- Weight - 248 kg



AIMPR
Lat Pull Down

- Size - 1190*1200*2230mm
- Weight Stack - 110 kg
- Weight - 275 kg



AIMPR
Vertical Press

- Size - 1435*1125*1530mm
- Weight Stack - 110 kg
- Weight - 281 kg



AIMPR
Seated Leg Curl

- Size - 1665*1145*1530mm
- Weight Stack - 110 kg
- Weight - 270 kg



AIMPR

Camber Curl

- Size - 1500*930*1530mm
- Weight Stack - 80 kg
- Weight - 192 kg



AIMPR

Vertical Row

- Size - 1505*1005*1530mm
- Weight Stack - 110 kg
- Weight - 245 kg



AIMPR

Long Pull

- Size - 1780*1320*1830mm
- Weight Stack - 110 kg
- Weight - 226 kg



AIMPR

Dip/Chin Assist

- Size - 1930*1000*2495mm
- Weight Stack - 110 kg
- Weight - 280 kg



EL SERIES

Explore elevated strength training with the EV Series. Crafted for peak gains and performance, these machines redefine your fitness accomplishments.



ht Your Every
 With EV Series

AIMEL

Chest Press

- Size - 1545*1150*1650mm
- Weight Stack - 100 kg
- Weight - 225 kg



AIMEL

Pectoral Fly

- Size - 1505*1245*1650mm
- Weight Stack - 100 kg
- Weight - 211 kg



AIMEL

Seated Row

- Size - 1050*1510*1650mm
- Weight Stack - 100 kg
- Weight - 221 kg



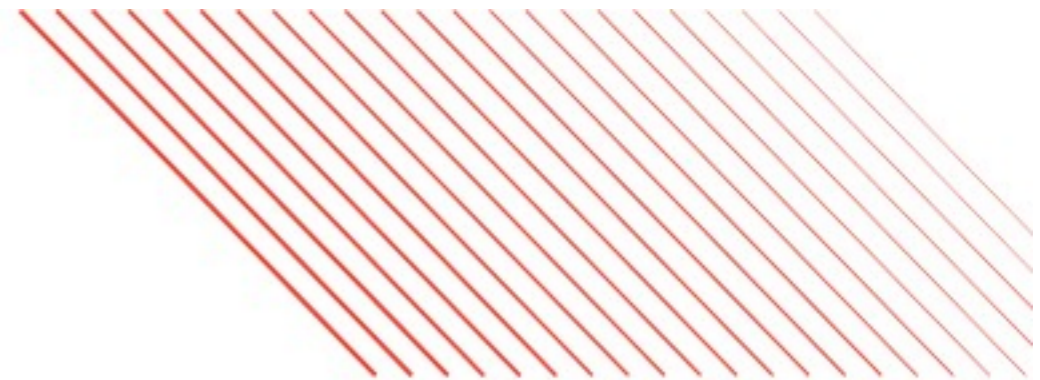

AIMEL
Biceps Curl

- Size - 1170*1365*1650mm
- Weight Stack - 100 kg
- Weight - 190 kg



AIMEL
Assisted Chin/Dip

- Size - 1475*1260*2335mm
- Weight Stack - 100 kg
- Weight - 267 kg



AIMEL
Abdominal Isolator/Hyper

- Size - 1225*1285*1650mm
- Weight Stack - 100 kg
- Weight - 204 kg



AIMEL
Triceps Curl

- Size - 1230*1695*1650mm
- Weight Stack - 100 kg
- Weight - 226 kg



AIMEL
Abdominal Crunch

- Size - 1190*1285*1650mm
- Weight Stack - 100 kg
- Weight - 168 kg



AIMEL

Rotary Torso

- Size - 1240*1250*1650mm
- Weight Stack - 100 kg
- Weight - 179 kg



AIMEL

Seated Horizontal Pulley

- Size - 980*1815*1650mm
- Weight Stack - 100 kg
- Weight - 199 kg



AIMEL

High Pulley

- Size - 980*1815*1650mm
- Weight Stack - 100 kg
- Weight - 199kg



AIMEL

Lat Pull Down

- Size - 1485*1850*2005mm
- Weight Stack - 100 kg
- Weight - 246 kg



AIMEL

Seated Leg Curl

- Size - 1215*1770*1650mm
- Weight Stack - 100 kg
- Weight - 230 kg



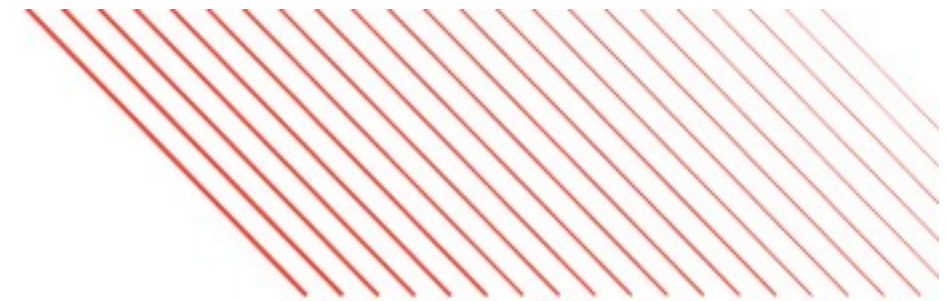

AIMEL

Horizontal Leg Curl

- Size - 1135*1700*1650mm
- Weight Stack - 100 kg
- Weight - 215 kg



AIMEL

Leg Press

- Size - 1115*1975*1650mm
- Weight Stack - 100 kg
- Weight - 254 kg



AIMEL

Leg Extension

- Size - 1150*1790*1650mm
- Weight Stack - 100 kg
- Weight - 235 kg



AIMEL

Multi Hip

- Size - 1095*1140*1635mm
- Weight Stack - 100 kg
- Weight - 212 kg

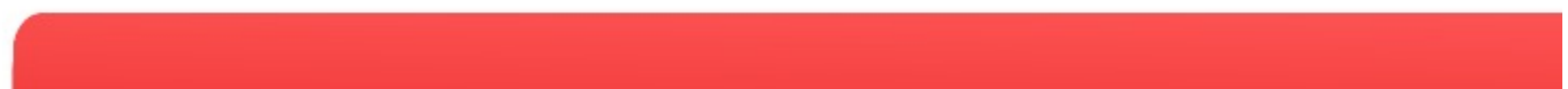

AIMEL

Standing Leg Extension

- Size - 950*1255*1650mm
- Weight Stack - 100 kg
- Weight - 186 kg



AIMEL

Inner Thigh Adductor

- Size - 1740*1235*1650mm
- Weight Stack - 100 kg
- Weight - 210 kg



AIMEL

Calf Extension

- Size - 1090*1600*1650mm
- Weight Stack - 100 kg
- Weight - 197 kg



AIMEL

Outer Thigh Abductor

- Size - 1730*1235*1650mm
- Weight Stack - 100 kg
- Weight - 202 kg



AIMEL

Shoulder Press

- Size - 1950*1460*1660mm
- Weight Stack - 100 kg
- Weight - 215 kg



AIMEL

Abdominal Isolator/Hyper

- Size - 1250*1250*1660mm
- Weight Stack - 100 kg
- Weight - 215 kg



AIMEL

Pec Fly/Rear Delt

- Size - 1505*1215*2000mm
- Weight Stack - 100 kg
- Weight - 226 kg



AIMEL

High Pulley Row

- Size - 1900*1520*2100mm
- Weight Stack - 100 kg
- Weight - 230 kg



AIMEL

Multi Press

- Size - 1950*1460*1660mm
- Weight Stack - 100 kg
- Weight - 215 kg



AIMEL

Biceps Triceps

- Size - 1250*1250*1660mm
- Weight Stack - 100 kg
- Weight - 210 kg



AIMEL

Abductor/Adductor

- Size - 1600*1000*1600mm
- Weight Stack - 100 kg
- Weight - 215 kg



AIMEL

Leg Curl Extension

- Size - 1400*1200*1660mm
- Weight Stack - 100 kg
- Weight - 245 kg



DS SERIES

DS SERIES BY FITNESS AIM IS UNIQUE SELECTION

for those valuing durability and excellence, comprising sturdy gym equipment built to last.



AIMDS

Rear Delt/Pec Fly

- Size - 1860*1310*2020mm
- Weight Stack - 110 kg
- Weight - 273 kg



AIMDS

Leg Extension & Leg Curl

- Size - 1650*1100*1510mm
- Weight Stack - 110 kg
- Weight - 261 kg



AIMDS

Chest & Shoulder Press

- Size - 1755*1450*1510mm
- Weight Stack - 110 kg
- Weight - 261 kg



AIMDS

Camber Curl & Triceps

- Size - 1430*1070*1510mm
- Weight Stack - 110 kg
- Weight - 239 kg



AIMDS

Vertical Row

- Size - 1490*1290*1513mm
- Weight Stack - 95 kg
- Weight - 231 kg



AIMDS

Long Pull

- Size - 1500*1300*1500mm
- Weight Stack - 140 kg
- Weight - 261 kg



AIMDS

Abductor/Adductor

- Size - 1620*835*1510mm
- Weight Stack - 93 kg
- Weight - 230 kg



AIMDS

Seated Leg Curl

- Size - 1650*990*1513mm
- Weight Stack - 110 kg
- Weight - 279 kg



AIMDS

Vertical Press

- Size - 1380*1330*1513mm
- Weight Stack - 110 kg
- Weight - 244 kg



AIMDS

Lat Pulldown

- Size - 1400*1200*1535mm
- Weight Stack - 110 kg
- Weight - 250 kg



AIMDS

Lateral Raise

- Size - 1020*1160*1513mm
- Weight Stack - 100 kg
- Weight - 52 kg



AIMDS

Prone Leg Curl

- Size - 1570*950*1513mm
- Weight Stack - 95 kg
- Weight - 216 kg



AIMDS

Lat & Pulley Machine

- Size - 1970*1350*2240mm
- Weight Stack - 110 kg
- Weight - 244 kg



AIMDS

Leg Extension

- Size - 1650*1100*1510mm
- Weight Stack - 110 kg
- Weight - 261 kg



AIMDS

Dip/Chin Assist

- Size - 1550*1370*2360mm
- Weight Stack - 88 kg
- Weight - 253kg



PH SERIES

FITNESS AIM offers best movements
fitness levels, facilitating full-body workouts with adjustable settings
and varied weights.



AIMPH

Chest Press

- Size - 1435*1445*1535mm
- Weight Stack - 100 kg
- Weight - 263 kg



AIMPH

Pectoral Fly

- Size - 1480*1235*1535mm
- Weight Stack - 100 kg
- Weight - 255 kg



AIMPH

Biceps Curl

- Size - 1135*1345*1535mm
- Weight Stack - 100 kg
- Weight - 222 kg



AIMPH

Seated Row

- Size - 1035*1555*1535mm
- Weight Stack - 100 kg
- Weight - 258 kg



AIMPH

Triceps Curl

- Size - 1255*1515*1535mm
- Weight Stack - 100 kg
- Weight - 245 kg



AIMPH

Shoulder Press

- Size - 1575*1565*1535mm
- Weight Stack - 100 kg
- Weight - 247 kg



AIMPH

Assisted Chin/Dip

- Size - 1455*1275*2335mm
- Weight Stack - 100 kg
- Weight - 319 kg



AIMPH

Outer Thigh Abductor

- Size - 1155*1650*1535mm
- Weight Stack - 100 kg
- Weight - 246 kg



AIMPH

Rotary Torso

- Size - 1225*1235*1535mm
- Weight Stack - 100 kg
- Weight - 214 kg



AIMPH

Lat Pull Down

- Size - 1465*1795*2005mm
- Weight Stack - 100 kg
- Weight - 275 kg



AIMPH

Abdominal Crunch

- Size - 1175*1280*1535mm
- Weight Stack - 100 kg
- Weight - 201 kg



AIMPH

Seated Horizontal Pully

- Size - 985*1830*1535mm
- Weight Stack - 100 kg
- Weight - 225 kg



AIMPH

High Pulley

- Size - 1370*1360*2210mm
- Weight Stack - 100 kg
- Weight - 280 kg



AIMPH

Horizontal Leg Curl

- Size - 1165*1700*1535mm
- Weight Stack - 100 kg
- Weight - 246 kg



AIMPH

Seated Leg Curl

- Size - 1240*1770*1535mm
- Weight Stack - 100 kg
- Weight - 249 kg



AIMPH

Leg Extension

- Size - 1190*1790*1535mm
- Weight Stack - 100 kg
- Weight - 265 kg



AIMPH

Leg Press

- Size - 1105*2045*1535mm
- Weight Stack - 100 kg
- Weight - 291 kg



AIMPH

Standing Leg Extension

- Size - 1005*1355*1535mm
- Weight Stack - 100 kg
- Weight - 229 kg



AIMPH

Multi Hip

- Size - 1085*1055*1590mm
- Weight Stack - 100 kg
- Weight - 241 kg



AIMPH

Calf Extension

- Size - 1075*1615*1535mm
- Weight Stack - 100 kg
- Weight - 250 kg



AIMPH

Inner Thigh Adductor

- Size - 1170*1670*1535mm
- Weight Stack - 100 kg
- Weight - 243 kg



AIMPH

Multi Press

- Size - 1950*1460*1535mm
- Weight Stack - 100 kg
- Weight - 240 kg



AIMPH

Pec Fly Rear Delt

- Size - 1505*1215*2000mm
- Weight Stack - 100 kg
- Weight - 242 kg



AIMPH

High Pulley Row

- Size - 1900*1520*2230mm
- Weight Stack - 100 kg
- Weight - 255 kg



AIMPH

Biceps Triceps

- Size - 1250*1250*1535mm
- Weight Stack - 100 kg
- Weight - 235 kg



AIMPH

Leg Curl Extension

- Size - 1400*1200*1535mm
- Weight Stack - 100 kg
- Weight - 250 kg



AIMPH

Abdominal Isolator/Hyper

- Size - 1250*1250*1535mm
- Weight Stack - 100 kg
- Weight - 240 kg



AIMPH

Abductor/Adductor

- Size - 1600*1000*1535mm
- Weight Stack - 100 kg
- Weight - 240 kg

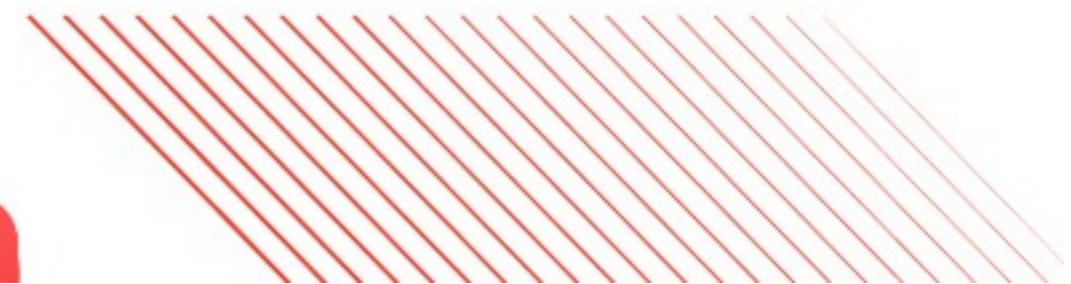



FITNESS AIM™

"Unleash your inner beast with FITNESS.AIM®"

PS SERIES

FITNESS AIM PS Series give best

fitness levels, facilitating full-body workouts with adjustable settings and varied weights.



AIMPS

Seated Chest Press

- Size - 1197*1436*1617mm
- Weight Stack - 100 kg
- Weight - 197 kg



AIMPS

Shoulder Press

- Size - 1344*1455*1617mm
- Weight Stack - 100 kg
- Weight - 186 kg



AIMPS

Seated Row

- Size - 1343*1300*1617mm
- Weight Stack - 100 kg
- Weight - 195 kg



AIMPS

Biceps Curl

- Size - 1344*1253*1617mm
- Weight Stack - 100 kg
- Weight - 200 kg



AIMPS

Upper Limbs

- Size - 1650*978*1580mm
- Weight Stack - 80 kg
- Weight - 215 kg



AIMPS

High Pully

- Size - 1258*1482*2241mm
- Weight Stack - 100 kg
- Weight - 206 kg



AIMPS

Horizontal Leg Curl

- Size - 1657*1215*1617mm
- Weight Stack - 100 kg
- Weight - 218 kg



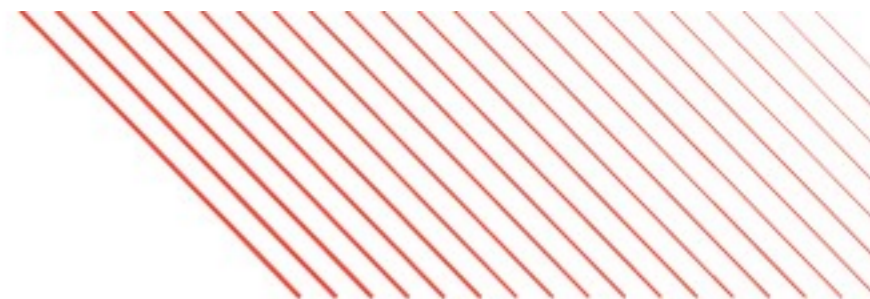

AIMPS

Leg Extension

- Size - 1441*1335*1617mm
- Weight Stack - 100 kg
- Weight - 214 kg



AIMPS

Pec/Dec Fly

- Size - 1688*1065*1994mm
- Weight Stack - 100 kg
- Weight - 212 kg



AIMPS

Multi Press

- Size - 1542*1336*1617mm
- Weight Stack - 100 kg
- Weight - 206 kg



AIMPS

Biceps & Triceps

- Size - 1344*1253*1617mm
- Weight Stack - 100 kg
- Weight - 200 kg



AIMPS

High & Low Row

- Size - 1860*1220*1930mm
- Weight Stack - 100 kg
- Weight - 255 kg



AIMPS

Leg Curl & Leg Extension

- Size - 1385*1336*1617mm
- Weight Stack - 100 kg
- Weight - 239 kg



AIMPS

Prone Leg Curl & Extension

- Size - 1385*1336*1617mm
- Weight Stack - 100 kg
- Weight - 262 kg



AIMPS

Adductor & Abductor

- Size - 1542*1370*1617mm
- Weight Stack - 100 kg
- Weight - 206 kg



SMITH MACHINE, FUNCTIONAL TRAINER AND RACKS

Smith Machine and Functional Trainer Offer Safe, Versatile Strength Training While The Rack Stores Equipment, Ensuring a Premium Listing Fitness Experience



AIMSR22

Power Rack



AIMSR14

Squat Rack



AIMSR01

**Half Rack with
Deadlift Platform**





FITNESS AIM

"Unleash your inner beast with FITNESS.AIM®"



AIMS63

Smith Machine



AIM S15

Power Rack + Smith



AIM S29

Smith + Power Rack



AIM S34

Smith Machine



AIM S63B3

Smith Machine with Rack



Functional Trainers

Weight Stack : 100 Kg Each Side



AIM S16



AIM S5



AIM S13





FITNESS AIM

"Unleash your inner beast with FITNESS AIM"



AIM H80
Robo Cross



AIM S18
Cable Cross Over

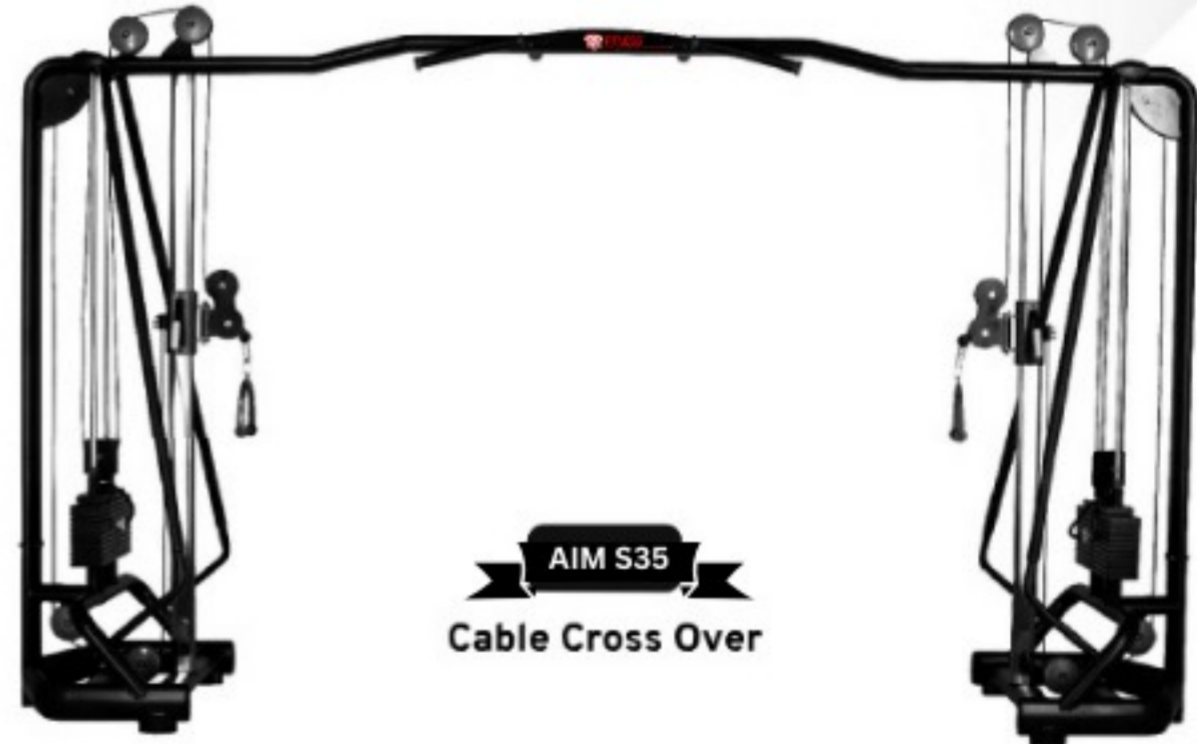

AIM S35
Cable Cross Over



AIM SF1
Functional Trainer + Smith

• Weight Stack : 100 Kg Each Side

AIM SF01

**Functional Trainer
+ Smith + Rack**

• Weight Stack : 100 Kg Each Side



AIM SF3

**Functional Trainer
+ Smith + Rack**

• Weight Stack : 100 Kg Each Side



LEG PRESS AND HACK SQUAT

Get powerful leg muscles with our Leg Press & Hack Squat series. Adjustable footplates and backrest provide a comfortable workout experience for users of all levels.



AIMPP22

Leg Press

AIMLP8

Leg Press



AIMLP22

Leg Press



AIMLP21

Leg Press



AIM S22B

Leg Press/Hack Squat



AIM V10

Leg Press



AIME57

Hack Squat



AIM V24

Vertical Leg Press



HSLP41

Leg Press/Hack Squat



AIM V04

Lateral Leg Press





FREE WEIGHT SERIES

TRAIN WITH FITNESS AIM





AIMFW1

Chest Press

Size - 1268*1953*1674mm



AIMFW2

Incline Chest Press

Size - 1357*2074*1851mm



AIMFW3

Shoulder Press

Size - 1558*1532*1510mm



AIMFW4

Low Row

Size - 1317*1390*1695mm



AIMFW5

Wide Chest Press

Size - 2019*1345*1797mm



AIMFW6

Row Machine

Size - 1571*1387*1322mm



AIMFW7

Pull Down

Size - 1937*1321*1846mm

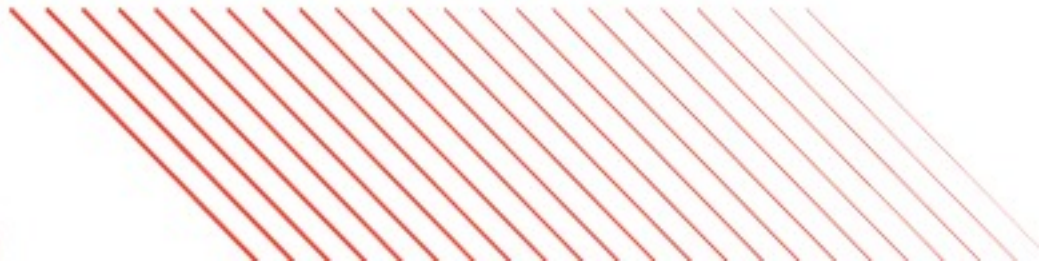

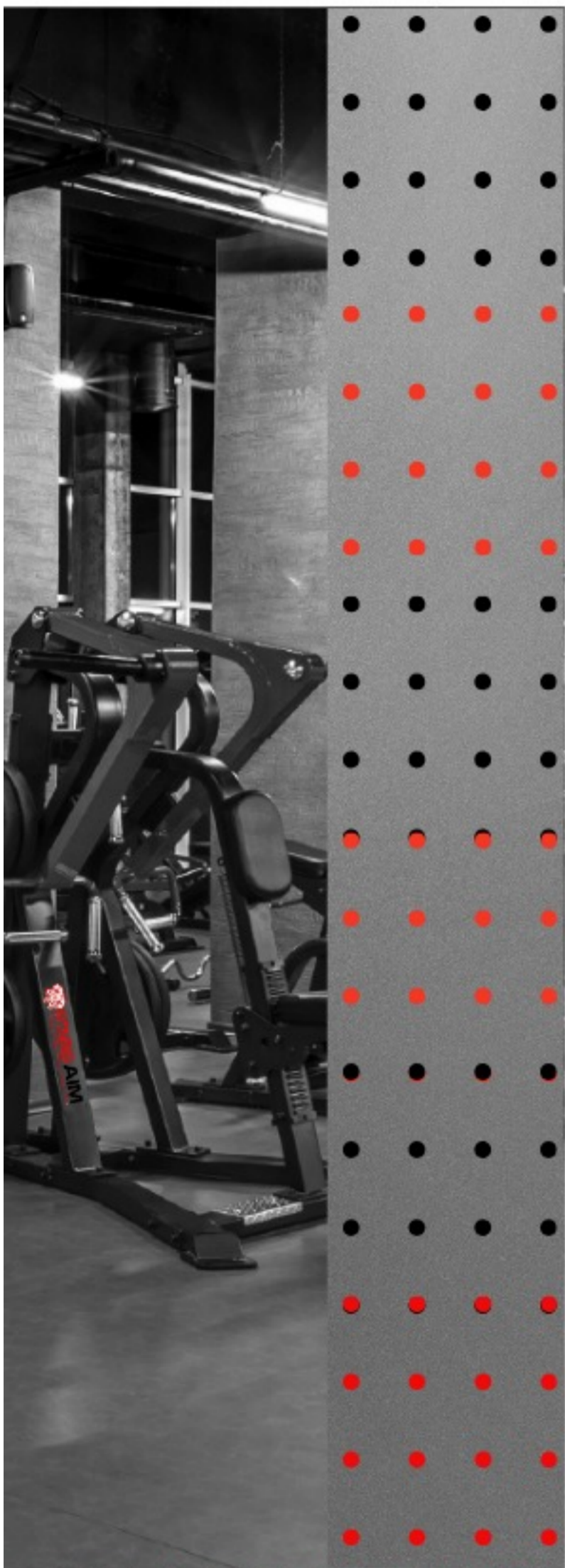
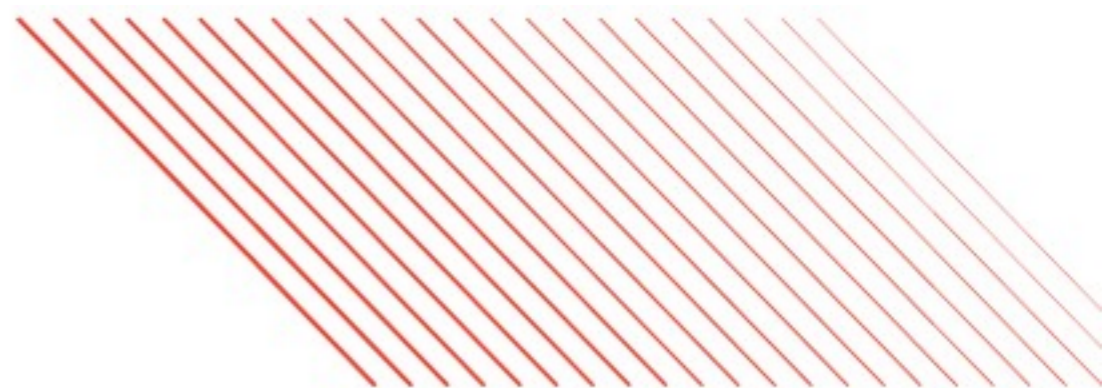

ISO-LATERAL BENCH PRESS

AIMFW8 Size - 1610*1480*2000mm



SEATED BICEPS

AIMFW9 Size - 1250*1500*1370mm



ISO-LATERAL DECLINE CHEST PRESS

AIMFW10 Size - 1780*1320*1760mm



ISO-LATERAL SUPER INCLINE PRESS

AIMFW11 Size - 1550*1250*1700mm



LATERAL RAISE

AIMFW12 Size - 1450*1280*1350mm



V-SQUAT

AIMFW13 Size - 2450*1500*1850mm



ISO-LATERAL KNEELING LEG CURL

AIMFW14 Size - 1920*1120*1460mm



ISO-LATERAL LOW ROW

AIMFW15 Size - 1430*1280*1700mm



PLATE-LOADED ISO-LATERAL ROW

AIMFW16 Size - 1530*1560*1350mm





ABDOMINAL OBLIQUE CRUNCH

AIMFW17 Size - 1700*1200*1580mm



ISO FLAT PRESS

AIMFW18 Size - 1481*1244*1461mm



SEATED LEG EXTENSION

AIMFW19 Size - 1845*1300*1057mm



SEATED TRICEP PRESS

AIMFW20 Size - 1700*1650*1047mm



ISO-LATERAL FRONT LAT PULLDOWN

AIMFW21 Size - 1780*1600*2020mm



PULLOVER

AIMFW22 Size - 1930*1700*1500mm



VERTICAL LEG PRESS

AIMFW23 Size - 1575*1850*2010mm



LAT PULLDOWN

AIMFW24 Size - 1800*1300*2000mm



SHOULDER PRESS

AIMFW25 Size - 1505*1005*1530mm



INCLINE PEC FLY

AIMFW26 Size - 1615*1464*1318mm



ISO LATERAL LEG EXTENSION

AIMFW27 Size - 1518*1462*1488mm



CHEST PRESS & LAT PULLDOWN

AIMFW28 Size - 2050*1780*2010mm



ISO-LATERAL BACK EXTENSION

AIMFW29 Size - 2100*2050*1170mm



ISO-LATERAL FRONT LAT PULLDOWN

AIMFW30 Size - 1640*1230*2070mm



ISO-LATERAL STANDING PEC FLY

AIMFW31 Size - 1200*1260*1550mm



HIP THRUST

AIMFW32 Size - 1950*1750*900mm



SITTING OUTER THIGH ABDUCTOR

AIMFW33 Size - 1500*1400*1300mm



ISO-LATERAL DECLINE PRESS

AIMFW34 Size - 1900*1345*1700mm



ISO-LATERAL STANDING LATERAL RAISE

AIMFW35 Size - 1200*1120*1350mm



T DEAD LIFT PRESS

AIMFW36 Size - 1910*910*1180mm



ISO-LATERAL WILD CHEST

AIMFW37 Size - 2230*1140*1760mm



BELT SQUAT

AIMFW38 Size - 1080*1100*1805mm



ISO-LATERAL CROSS LAT PULLDOWN

AIMFW39 Size - 1550*1300*1850mm



PENDULUM LEG PRESS

AIMFW40 Size - 1850*900*1450mm

BENCHES

Experience superior comfort and stability during workouts with our premium-quality benches, designed to maximize your fitness potential.



DL BENCH



AIMDLB1

Olympic Flat Bench



AIMDLB3

Olympic Decline Bench



AIMDLB3

Olympic Incline Bench



AIMDLB4

Seated Calf Raise



AIMDLB5

Hyper Extension



AIMDLB8

Flat Bench



AIMDLB6

Adjustable Web Board



AIMDLB9

Stool



AIMDLB7

Adjustable Bench



AIMDLB10

Preacher Bench





FITNESS AIM
"Unleash your inner beast with FITNESS AIM"

AL BENCH



AIMALB1

Olympic Flat Bench



AIMALB4

Adjustable Bench



AIMALB2

Olympic Incline Bench



AIMALB5

Adjustable Bench



AIMALB3

Olympic Decline Bench



AIMALB6

Stool



AIMALB7

Flat Bench



AIMALB10

Preacher Bench



AIMALB8

AB Board



AIMALB11

Parallel Bar + Chin Up



AIMALB9

Hyper Extension



AIMALB12

Seated Calf Raise



SM BENCH



AIMSMB1

Olympic Flat Bench



AIMSMB4

Olympic Multi Bench



AIMSMB2

Olympic Incline Bench



AIMSMB5

Preacher Bench



AIMSMB3

Olympic Decline Bench

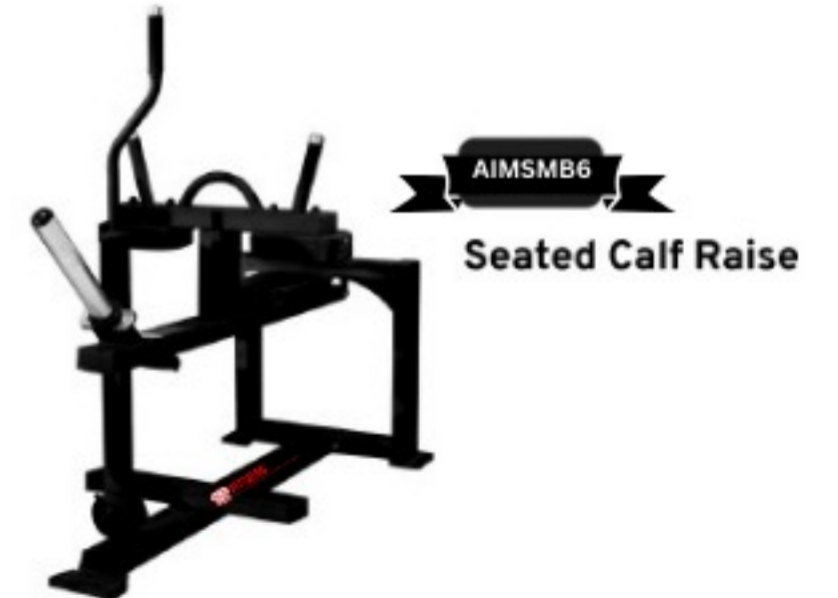

AIMSMB6

Seated Calf Raise

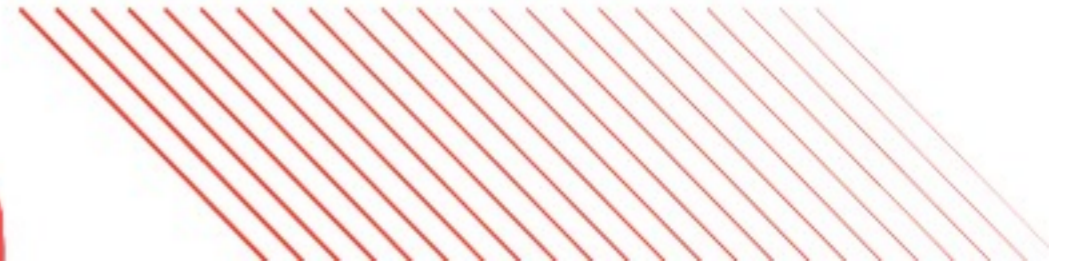



Vertical Knee Raise

AIMSMB7



Flat Bench

AIMSMB10



Adjustable Bench

AIMSMB13



Hyper Extension

AIMSMB8



AB Board

AIMSMB11



Adjustable Bench

AIMSMB14



Stool

AIMSMB9



Ladder AB Board

AIMSMB12



Adjustable Bench

AIMSMB15



AIMSSQ

Super Squat



AIMSSQ1

Super Squat



AIMHTB

Hip Thrust with Belt



AIMDLR

Dual Lateral Raise



AIMSHA

Standing Hip Abductor



AIMVCP

Versa Chest Press



AIMSMF

Standing Multi Flight



AIMABT

**Rectus Abdominis
Trainer**

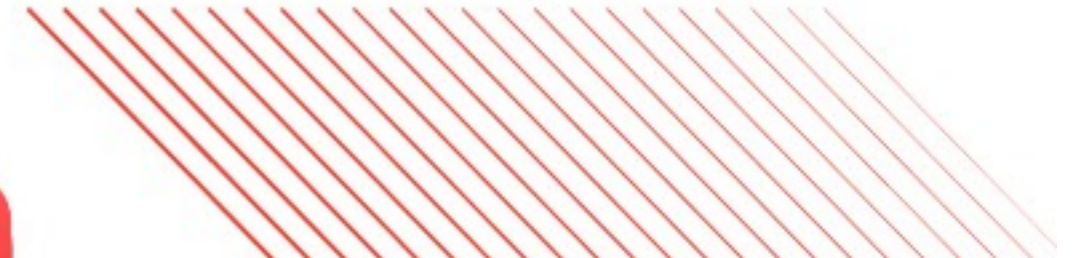

AIMOR1
T-Bar Holder

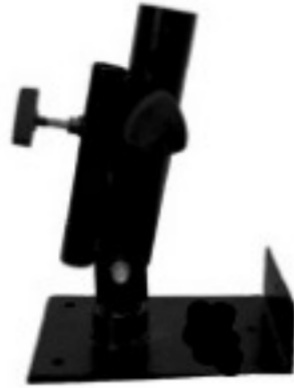

AIMAOR4
Wrist Curl
Weight Stack : 40 Kg



AIMOR2
T-Bar Row with Chest Support



AIMOR5
Double Twister



AIMOR3
T-Bar Row with Platform



AIMOR6
Sissy Squat





AIMR1
Curling Stand



AIMR2
Curling Stand



AIMR3
Wall Rod Stand



AIMR4
Rod Stand



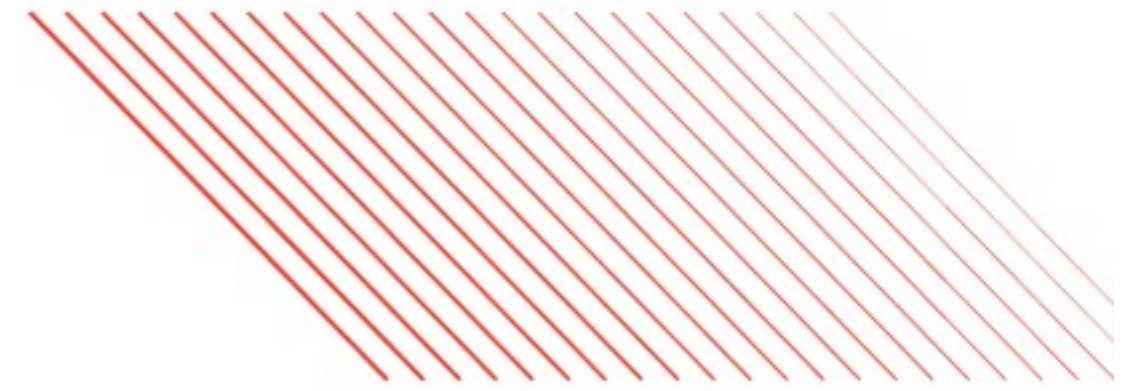

AIMR5

Fixed Barbell Rack



AIMR6

Fixed Barbell Rack



AIMR7

Bumper Plate Rack



AIMR8

Plate Tree Rack



AIMR9

Dumbbell Rack 2 Tier



AIMR10

Dumbbell Rack 2 Tier



AIMR11

Dumbbell Rack 3 Tier



OTHER RANGE

OTHER RANGE AVAILABLE
AT FITNESS AIM



AIMAOR7

Gym Fan



AIMAOR10

Sledge



AIMAOR8

Standing Preacher bench



AIMAOR11

Tank Sled



AIMAOR9

Deadlift Platform



AIMAOR12

Glute Ham Developer



CARDIO

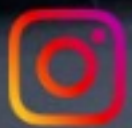

@FITNESS._AIM



FITNESS AIM

"Unleash your inner beast with FITNESS AIM"



TREADMILL SERIES



FITNESS AIM
Unleash your inner beast with FITNESS AIM

MODEL:- AIM U LEGEND



Optional Android Display

Motor	5 HP - 10 HP
Speed	01 - 20 KM/H
Incline	0 - 15 levels Auto
Running Surface	600mm x 1554mm
Max User Weight	200 KGs
Display Features	Time, Distance, Speed, Calories, & Pulse.



MODEL:- AIM DL800



Motor	8HP (4HP Continuous) AC
Speed	01 - 20 KM/H
Incline	1 - 20 Levels Auto
Running Surface	585 x 1550mm
Max User Weight	200 KGs
Display Features	Time, Distance, Speed, Calories, & Pulse.



MODEL:- AIM SERIES X30



Motor	8HP (4HP Continuous) AC
Speed	01 - 20 KM/H
Incline	0 - 20 levels Auto
Running Surface	560mm x 1665mm
Max User Weight	200 KGs
Display Features	Time, Distance, Speed, Calories, & Pulse.



MODEL:- AIM SERIES X10



Motor	8HP (4HP Continuous) AC
Speed	01 - 20 KM/H
Incline	0-15 levels
Running Surface	520mm x 1500mm
Max User Weight	200 KGs
Display Features	Time, Distance, Speed, Calories, & Pulse.



MODEL:- AIM PANTHER



Motor	8HP (4HP Continuous) AC
Speed	01 - 20 KM/H
Incline	0 - 20 levels Auto
Running Surface	600 mm x 1530mm
Max User Weight	200 KGs
Display Features	Time, Distance, Speed, Calories, & Pulse.



MODEL:- AIM MONSTER



Motor	8HP (4HP Continuous) AC
Speed	01 - 20 KM/H
Incline	1 - 20 levels Auto
Running Surface	525mm x 1610 mm
Max User Weight	200 KGs
Display Features	Time, Distance, Speed, Calories, & Pulse.



MODEL:- AIM OMEGA 2.0



Motor	8HP (4HP Continuous) AC
Speed	01 - 20 KM/H
Incline	0 - 20 levels Auto
Running Surface	535mm x 1550mm
Max User Weight	200 KGs
Display Features	Time, Distance, Speed, Calories, & Pulse.



MODEL:- AIM THOR



Motor	8HP (4HP Continuous) AC
Speed	01 - 20 KM/H
Incline	1 - 20 levels Auto
Running Surface	590mm x 1620mm
Max User Weight	200 KGs
Display Features	Time, Distance, Speed, Calories, & Pulse.



MODEL:- AIM ULTRA 2



Motor	4HP- 8HP
Speed	01 - 20 KM/H
Incline	1 - 20 levels Auto
Running Surface	1560mm x 840mm
Max User Weight	200 Kgs
Display Features	Time, Distance, Speed, Calories, & Pulse.



MODEL:- AIM SERIES D 2



Motor	8HP (4HP Continuous) AC
Speed	01 - 24 KM/H
Incline	1 - 20 levels Auto
Running Surface	584mm x 1575mm
Max User Weight	200 KGs
Display Features	Time, Distance, Speed, Calories, & Pulse.
Special Feature	Rhymebus Inverter



MODEL:- AIM CANNON 2



Belt Technology - Aluminium

Six Level of Resistance

Innovative Curved Deck

Max User Weight - 180kg

Display Features - Time, Distance, Speed, Calories, & Pulse.

Non Motorized Treadmill



MODEL:- AIM CANNON 1



Belt Technology - Nylon

Six Level of Resistance

Innovative Curved Deck

Max User Weight - 150kg

Display Features - Time, Distance, Speed, Calories, & Pulse.

Non Motorized Treadmill

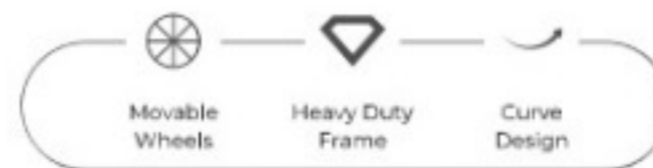



FITNESS AIM™

"Unleash your inner beast with FITNESS AIM®"

ELLIPTICAL SERIES

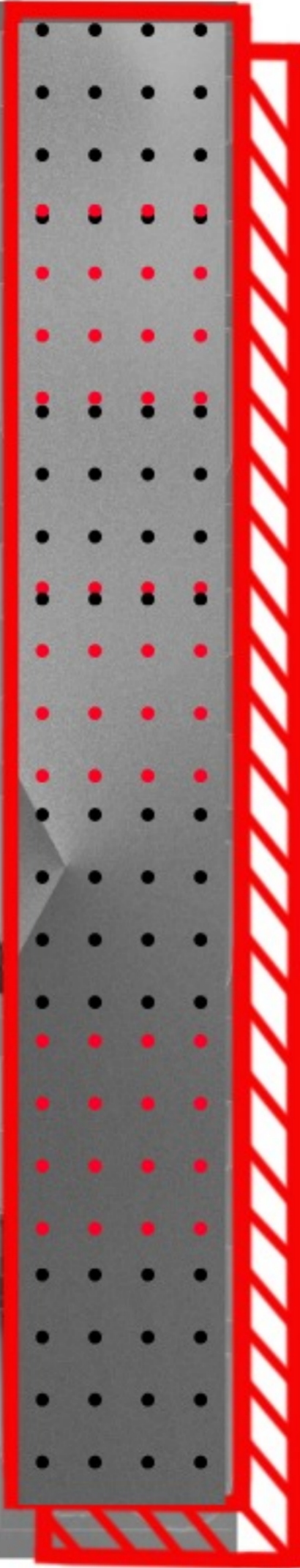

MODEL:- AIM SERIES CT15



Motor System	Self-Generated
Dimension	2180*746*1780mm
Slope	Fixed
Color	Black, Silver.
Weight	135 KGs
Max User Weight	200 KGs



MODEL:- AIM SERIES CT 3



Fly Wheel	14KG Motor Magnetic (Auto Generate)
Transmission System	V Belt
Resistance Level	16 level Magnetic
Max User Weight	200 KGs
Display Features	Time, Speed, Distance, Calories, ODO & Pulse.

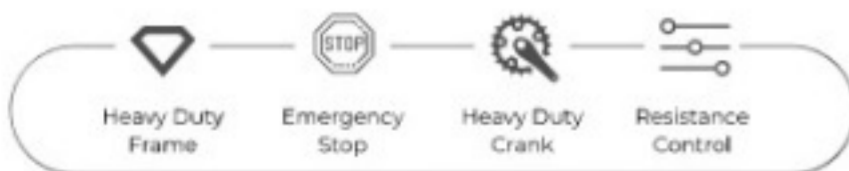

MODEL:- AIM SERIES CT 04



Fly Wheel	10KG Motor Magnetic
Product Weight	Net weight: 110KG ; Gross weight: 140KG
Item Size	2000*600*1700mm
Resistance	Magnetic
Max User Weight	180 KGs
Display Features	Time, Speed, Distance, Heart Rate



MODEL:- AIM SERIES CT 6



Fly Wheel	Eddy Mechanism 7KG
Track	Double track
Stride	20 inches
Incline	3 levels of manual incline (0-15%)
Resistance Level	24 levels of digital resistance
Product size	1775*726*1714mm
Product Weight	Net weight: 88KG ; Gross weight: 107KG
Max User Weight	180 KGs
Display Features	Time, Distance, Speed, Calories, & Pulse.



MODEL:- AIM SERIES CT 02



Fly Wheel	Eddy Mechanism 5KG
Track	Single track
Stride	20 inches
Resistance Level	24 levels of digital resistance
Product size	1721*724*1637mm
Product Weight	Net weight: 78KG ; Gross weight: 95KG
Max User Weight	150 KGs
Display Features	Time, Distance, Speed, Calories, & Pulse.

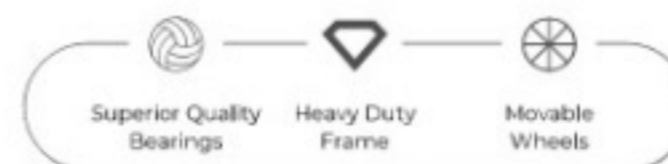

MODEL:- AIM SERIES CT 2



Fly Wheel	12KG Motor Magnetic
Transmission System	V Belt
Resistance Level	32-grade
Max User Weight	140 KGs
Display Features	Time, Distance, Speed, Calories, & Pulse.

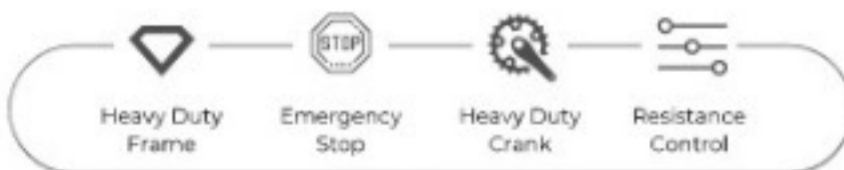

MODEL:- AIM SERIES CT 5



Fly Wheel	12KG Motor Magnetic
Transmission System	V Belt
Resistance Level	8 Level Manual
Max User Weight	180 KGs
Display Features	Time, Speed, Distance, Calories, ODO & Pulse.



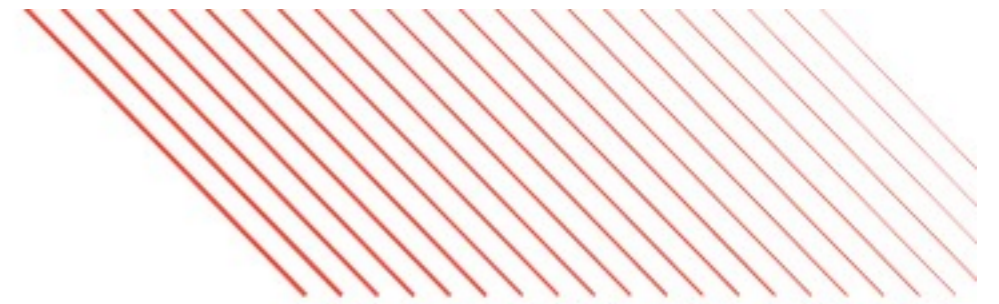

CYCLING SERIES



MODEL:- AIM SERIES SP A1/R1



Motor System	Self-Generated
Resistance Level	16-grade
Display Features	Time, Distance, Speed, Calories, Resistance Level, RPM & Pulse.
Max User Weight	160 KGs
Assembly Space	1205*550*1560(mm) 1205*620*1050(mm)



MODEL:- AIM SERIES SP2/RB1



Training Intensity	8 Levels by Manual
Max User Weight	130 KGs
N.W / G.W	34.5 / 38.8 KGs
Display Features	Time, Speed, Distance, Calories, Pulse Recovery, Body Fat, Temp.

Fly Wheel	8 Kgs
Training Intensity	10 Levels by Manual
Max User Weight	150 KGs
N.W / G.W	47.5/54.5 KGs
Display Features	Time, Speed, Distance, Calories, Pulse Recovery, Body Fat.



MODEL:- AIM SERIES SMB 1



Fly Wheel	25 KGs
Drive System	Magnetic
Seat	Adjustable
Max User Weight	200 KGs



MODEL:- AIM SERIES SP3



Fly Wheel	4 KG Aluminum
Brake System	Magnetic
Dimension	1260*500*1000mm
Product Weight	42 KGs
Colour	Black

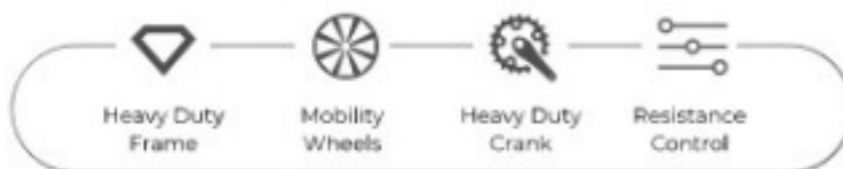

MODEL:- AIM SERIES SP04



Fly Wheel	18 KGs
Drive System	Magnetic
Seat	Adjustable
Max User Weight	200 KGs



MODEL:- AIM SERIES SP3



Fly Wheel	22 KGs
Drive System	Belt
Seat	Adjustable
Max User Weight	180 KGs
Color Option	Black, Yellow.



MODEL:- AIM SERIES SP3



Fly Wheel	18 KGs
Drive System	Belt
Seat	Adjustable
Max User Weight	180 KGs
Display Features	Time, Distance, Speed, Calories, & Pulse.



**BEST QUALITY
 CARDIO
 EQUIPMENTS**



MODEL:- AIM SERIES AR1



- Solid Steel Frame
- High Quality Contoured Seat
- Adjustable Foot Rest
- LCD Monitor That Displays All Workout Data
- 8 Level Resistance



MODEL:- AIM SERIES AR2



- N. W/G.W:53KG/60KG
- Product size: 1360*550*800mm
- Adjustable Foot Rest
- LCD Monitor That Displays All Workout Data



MODEL:- AIM SERIES SP04



Step Area	2270*800*1830mm
Rated Voltage	220V
Max User Weight	150 KGs
L.W.H	1450 x 880 x 2140 mm
Display Features	Speed level, Calories, Time, Distance, Steps, etc.



MODEL:- AIM SERIES SP04



Core & Abdominal Trainer
Heavy Duty Construction
Plate Loading Facilities
Max User Weight - 160 KG



MODEL:- AIM SERIES WR1



Core & Abdominal Trainer

Heavy Duty Construction

Plate Loading Facilities

Max User Weight - 160 KG



MODEL:- AIM SERIES WR2.0



American Ash/Oak Wood Frame

High Quality Contoured Seat

Adjustable Foot Rest

LCD Monitor That Displays All Workout Data

Max User Weight - 160 KG



MODEL:- AIM SERIES SEP



- Belt + Chain Driven
- High Range of Motion
- LCD Monitor That Displays All Workout Data
- Max User Weight - 160 KG
- 8 Level Resistance



MODEL:- AIM SERIES AB01



- Heavy Duty Construction
- Belt + Chain Driven
- High Range of Motion
- LCD Monitor That Displays All Workout Data
- Max User Weight - 160 KG



MODEL:- AIM SERIES AB02



- Heavy Duty Construction
- Belt + Chain Driven
- High Range of Motion
- LCD Monitor That Displays All Workout Data
- Max User Weight - 180 KGs



MODEL:- AIM SERIES TF1



- Heavy Duty Construction
- Plate Loading Ability
- High Quality Powder Coated Paint
- 2 Battle Rope Anchor Points

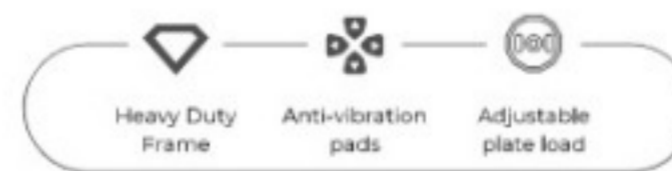



FITNESS AIM™

"Unleash your inner beast with FITNESS AIM!"



MASSAGER

SERIES

MODEL:- AIM SERIES VB1



Mode	Multiple Levels
Max user weight	150 KGs
Display Features	Time, Pulse, Calories, etc.



Heavy Duty
Frame



Anti-vibration
pads



Quiet
Operation

MODEL:- AIM MASSAGER EL1



Full Body Air Bag
Back Heating (Improve Metabolic Cycle)
137cm 25L Rail release the pressure of whole Body
New Leg Kneading Concept
Massage Hand detect & improve the massage
Closed feet with 3 groups of Roller
Premium Upholstery



LED Lights



Voice
control



USB
Recharge



Bluetooth
Audio



12 Automatic
Modes



FITNESS AIM

"Unleash your inner beast with FITNESS AIM"



PILATES

Elevate your fitness and Aerobic training programs
with FITNESS AIM Pilates Series

 **FITNESS AIM**

CADILLAC

- Wood = Maple
- Thickness = 3.5mm
- Dimensions = 2440*850*410



CORRECTOR

- Wood = Maple
- Thickness = 3.5mm
- Dimensions = 820*530*330



REFORMER WITH TOWER

- Wood = Maple
- Thickness = 3.5mm
- Dimensions = 2540*780*395



PILATE CHAIR

- Wood = Maple
- Thickness = 3.5mm
- Dimensions = 900*660*645



PILATE REFORMER

- Wood = Maple
- Thickness = 3.5mm
- Dimensions = 2540*780*395



LADDER BRIDGE

- Wood = Maple
- Thickness = 3.5mm
- Dimensions = 1150*720*1020





FITNESS AIM

"Unleash your inner beast with FITNESS AIM"



CROSSFIT RANGE



@FITNESS_AIM



FITNESS AIM

"Unleash your inner beast with FITNESS AIM"

AIMBETA

SIZE: 14*4.5*11 FEETS



AIMAPLHA

SIZE: 14*4.5*8 FEETS



AIMDELTA

SIZE: 24*5*10 FEETS

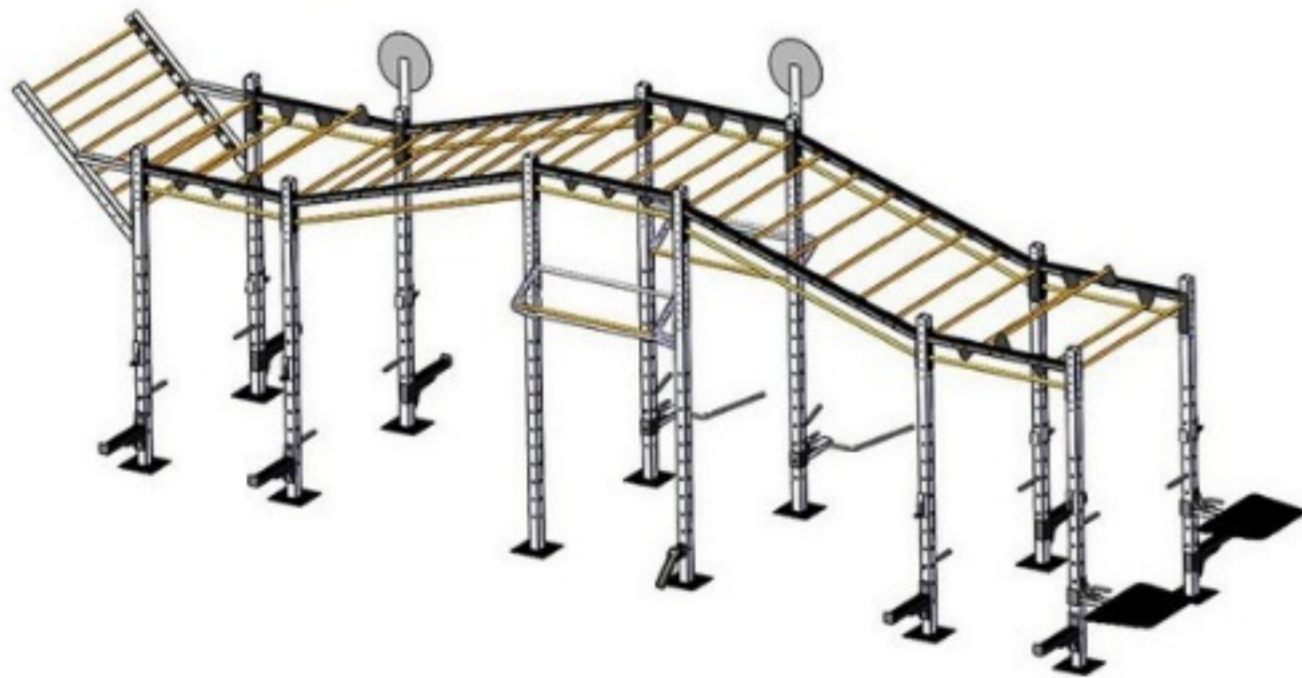

FITNESS AIM
"Unleash your inner beast with FITNESS AIM"

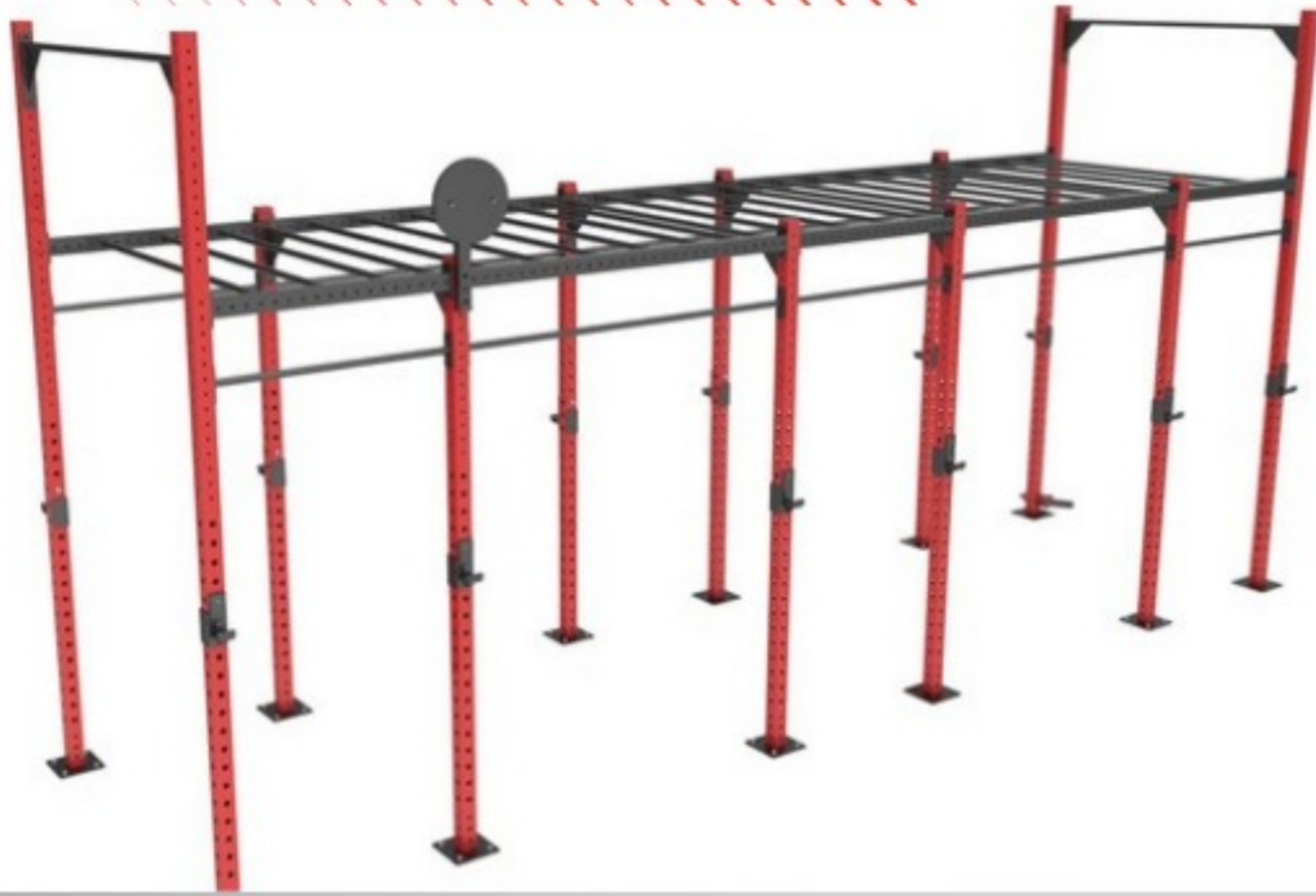

AIMAPLHAS

SIZE: 24*4.5*9 FEETS



AIMZETA

SIZE: 24*9*11 FEETS



AIMGAMMA

SIZE: 30*4.5*11 FEETS

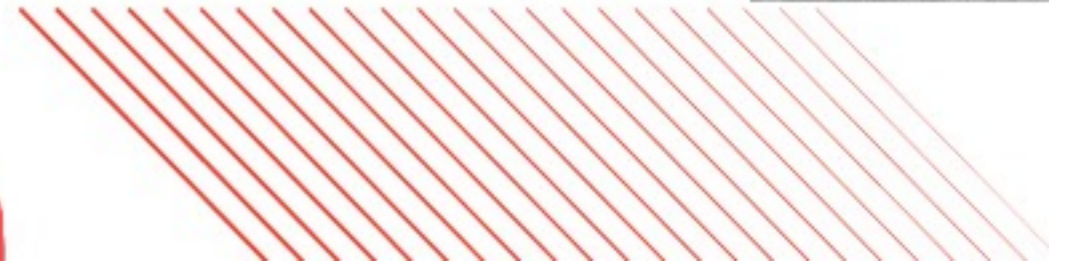

THANKYOU

We extend our heartfelt gratitude to each and every one of you for taking the time to explore our catalogue. Your interest in FITNESS AIM products is truly appreciated, and we are honored to have had the opportunity to showcase our extensive range of premium physical fitness goods to you.

As we strive to continually innovate and elevate our offerings, your feedback and support serve as invaluable sources of inspiration. We are committed to exceeding your expectations and delivering products of the highest quality that cater to your diverse fitness needs.

Thank you for considering FITNESS AIM for your fitness equipment requirements. We are eagerly looking forward to the opportunity to serve you and fulfill your orders with the same dedication and excellence that we pour into every aspect of our business.

Should you have any questions or require further assistance, please do not hesitate to reach out to us. Your satisfaction is our utmost priority, and we are here to ensure a seamless and enjoyable shopping experience for you.

Once again, thank you for choosing FITNESS AIM. We eagerly anticipate the opportunity to partner with you on your fitness journey and contribute to your pursuit of a healthier, fitter lifestyle.

With Regards,

Team

FITNESS AIM

Phone/Whatsapp :- +91-8384839044

EMAIL:- arawat.international@gmail.com

